

The Journal of Borderland Research

TABLE OF CONTENTS

HEALING WITH COLORED COTTONS AND COILS
By James Brownlee. 1 - 4

AN INITIATE AT WORK
From Peters' "Gurdjieff Remembered". 5 - 9

INTERSTELLAR COMMUNICATION SIGNALS
By L.G. Lawrence 10 - 14

THE TRUTH FINDERS, The Albigenses
By New Zealand Correspondent 15 - 16

THE KINSHIP OF RELIGION AND SCIENCE
Part V, By Robert W. Wilson. 17 - 19

CLIPS, QUOTES & COMMENTS
Interplanetary Communication, Sudden Loss of
Binding Force?, The Santa Cruz Mystery Spot,
"The Psychic World of Doc Anderson", Guardian
UFOs On Duty Overhead, Picture of the Yada di
Shi'ite, The Fifth Kingdom Is World Disciple-
ship, The New Group Of World Servers, The Prom-
ise and the Danger of Radionics, Apollonius,
Oracle For Vespasian, The Food and Drug Water-
gaters, California Is Not Beautiful, Washington
Is Not Beautiful Either, The Degrees Of The
Zodiac Symbolized, A Rocky Eminence In The
Midst Of A Turbulent Sea, Key Watergate Fi-
gure Doomed, Kether the Crown, God the Créa-
tor, Defects of the First Ray Types, Project
Hermes: Telecommunications, Tesla On Inter-
Planetary Communications, Crabb and Coming
Lecture Communications, Literature 20 - 36

THE JOURNAL OF BORDERLAND RESEARCH

BSRF No. 1 Published by Borderland Sciences Research Foundation, Inc., PO Box 548, Vista, California 92083 USA. Edited by the Director, Riley Hansard Crabb, Doctor of Metaphysics in the Society of St. Luke the Physician.

The Journal is published six issues a year with the assistance of the Associates, at the Director's home, 1103 Bobolink Drive, Vista. It is printed, 36 pages an issue. The Foundation was incorporated under California law, May 21, 1951, #254263, and has been in continuous existence since then. Address all correspondence to the PO Box. The Journal is included in the Foundation membership of \$7.00 a year. Single copies and back issues of the Journal are now \$1.50 each. If you don't care to join you may receive the Journal by donating \$7.00 a year or more to the Foundation. The Director's wife, Ms. Judith Crabb, is office manager and Secretary-Treasurer.

PURPOSES OF BSRF: This is a non-profit organization of people who take an active interest in unusual happenings along the borderland between the visible and invisible worlds. In the words of the late Meade Layne, founder and director of BSRA from 1946 to 1959: "BSRA publications are scientific in approach but employ few technical expressions. They deal with significant phenomena which orthodox science cannot or will not investigate. For example: The Fortean falls of objects from the sky. Teleportation, Radiesthesia, PK Effects, Underground Races, Mysterious Disappearances, Occult and Psychic Phenomena, Photography of the Invisible, Nature of the Ethers and the problem of the Aeroforms (Flying Saucers). In the year 1946 BSRA obtained an interpretation of the phenomena which since has come to be known as the Etheric or 4-D interpretation, and which has not been radically altered since that time. This continues to be the only explanation which makes good science, sound metaphysics and common sense."

The chief present concern of the Foundation is to make this kind of unusual information available as a public service at reasonable cost. Headquarters acts as a receiving, coordinating and distributing center. An important part of the Director's work is to give recognition, understanding and encouragement to people who are having unusual experiences of the borderland type and/or are conducting research in any of the above fields. For consultation on borderland problems, or for Spiritual healing through prayer, write or phone 714-724-2043 for help or for an appointment. Donations and bequests toward Foundation research programs and expenses are welcome.

The 24-page list of BSRF publications is available from Headquarters for 50¢ in coin or stamps. This includes mimeo brochures on borderland subjects, tape recordings of Mr. Crabb's lectures and of members of the Inner Circle, talking through trance-medium Mark Probert. Write to BSRF, PO Box 548, Vista, California 92083 USA.

HEALING WITH COLORED COTTONS AND COILS

By James Brownlee
New Zealand Associate

The late Herbert George was the first man to the writer's knowledge to discover that diseases and other bodily conditions could be treated through the use of colored cottons.

His reasoning was along the classical lines in this general field of healing, namely, that each part of the human body responds to a particular vibration, or frequency. He explored and verified the principle that a colored cotton of a similar vibration to the part of the body requiring attention, would normalize that part of the body when brought into relationship with a suitable "witness" from the patient.

The equipment required is extremely simple. An embroidery cotton card showing the various colors and the manufacturer's numbers alongside the samples is used. The most popular type in New Zealand is that produced by the Scottish firm of Clark and Co., whose products are widely distributed in the United States as well. For those who cannot obtain the Clark cottons in their areas, they can be obtained by writing to Clark and Company, Anchor Mills, Vorthwell Street, Glasgow, Scotland. Ask for Color Card No. 101 and the name of their nearest agent for their cottons wherever you may be living.

The other items required are a pendulum, a piece of black vitriolite glass about a foot square, a small probe or pencil and a "witness" or suitable link to the patient. The pendulum may be any design suited or convenient to the operator.

Black vitriolite is used because it is neutral and keeps the area where the experimenting is performed clear of other radiations. The operator first clears this plate, making sure that it is completely free of foreign matter and dust.

Assume that a diagnosis has been performed on the patient, and it has been found that the patient's liver needs attention as it is under-functioning. The operator places a "witness" of the patient, preferably a spot of blood held as a crystal in a piece of blotting paper, on the black plate with the color card alongside. The operator holds the pendulum over the witness and holds the probe or pencil in his other hand over the color card.

The operator then mentally asks for the colors required for this patient to correct the liver. Placing the probe on the first color he asks, "Is this the color required?" If the pendulum gives a negative reaction, under whatever system of responses the operator has set up in using the pendulum, he passes on to the next color. Here he repeats the process.

Whenever a positive reaction is obtained, the operator makes a note of the color by its number, and passes on to the next color. In some cases, only one color will provide a positive reaction, but in other cases, several colors may respond. When the operator has completed his run over the color card, the operator may then ask the pendulum if any other colors are needed. This is to ensure against having overlooked any color. If the answer is negative, the operator knows that the first stage has been completed correctly. If the answer is positive, he re-traces his progress through the color card until he finds the additional color helpful to the patient.

The next step is to find the length of cottons selected. The operator places a hank of embroidery cotton on the plate and then asks the pendulum how many feet are required. This length is arrived at by asking eliminative questions of the pendulum, such as "Does the patient require over 20 feet?", and then downward or upward in steps as the pendulum indicates, until the right footage is obtained. Then the process is repeated for inches and fractions of inches until finally some quite specific length of cotton is arrived at, say, 8 feet 6.3 inches.

The process is repeated for all the colors indicated as required for the patient's treatment. There is only one color on the plate at one time, and this is a condition that must be strictly observed.

Finally all the indicated lengths of all the required colors are joined together by tying them end to end with small knots so that a complete circle is formed. This circle, which may be quite large in some cases, is then reduced by looping in the fingers until it is about 1.25 inches in diameter. A piece of white, gummed paper is then placed around the cotton, labelled with the patient's name, and this both holds and identifies the treatment cotton.

A second method of finding cotton lengths is to spread a length of cotton out on the floor, and then run the pendulum along it, asking for the required length. The pendulum reacts at the required distance. This method, while cumbersome in some respects, acts as a useful check on the other method described.

THE MANY USES OF COLOR

Operators with Radionic Diagnostic Machines can set the dials to the rate of the conditions to be treated, and then use the cursor, or probe, as the case may be, to find the required colors.

Colors can be made up for minerals, biochemics and homeopathic preparations. They can be made up for plant diseases, and for all manner of agricultural purposes including the treatment of farm animals. In the latter application, this method has thoroughly proved itself under practical farming conditions in New Zealand. Such normally devastating animal ailments as facial eczema and bloat have been successfully treated by the writer and others.

As long as a person has knowledge of radiesthesia and can use a pendulum successfully, with a little practice it is very easy to make

up the color circles as described. Proficiency naturally increases with practise, as with everything else. Once the color circle is made for the patient, it is connected to the patient via the witness; or treatment can be carried out with the #1 Coil, made as follows:

1. Take a suitable wooden former 5.5 inches long and 1.75 inches in diameter. Then take a length of 16, 18 or 20 gauge, cotton-covered wire, and prove by pendulum which is the positive end of the wire. All lengths of wire have polarity. After locating the positive end, mark it.

2. Wind the wire 67 turns around the coil former, the direction of the turns being of no consequence. Bare the positive end of the wire where it leaves the former about one inch and solder onto a plate of tin or copper about two inches square, bent to form a small trough. This trough is to hold the colors.

3. Bare the negative end of the wire about one inch and solder onto a one inch diameter copper disc at the front end of the former.

4. Mount the whole coil on a wooden base, as shown in schematic at left.

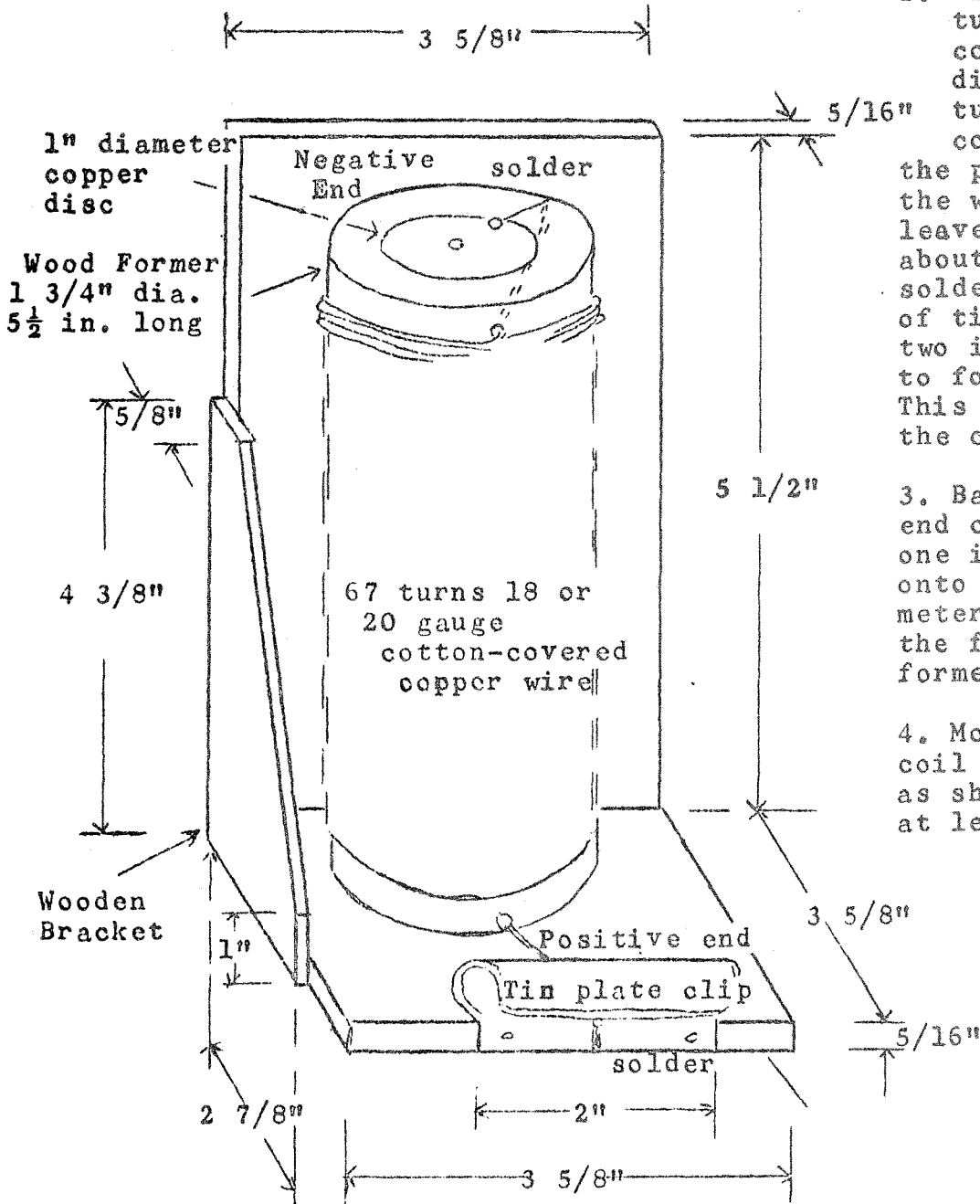

Having completed the construction of the coil, the device is ready to treat the patient as follows:

1. Place the color circle in the trough and face the negative end of the coil towards the patient.
2. See that the patient is about 3 ft. away from the coil.
3. Check with the pendulum for the correct treatment time for the patient, say 5, 10, 15 or 20 minutes and follow this time factor.

For the #2 Projector Coil for gardens, stock and similar applications, the coil is made according to the detailed drawing below. With this coil the colors are placed in the cutaway, and the negative end of the coil is faced towards the area to be treated. These coils cover a very large area and for the average section of land only two are needed.

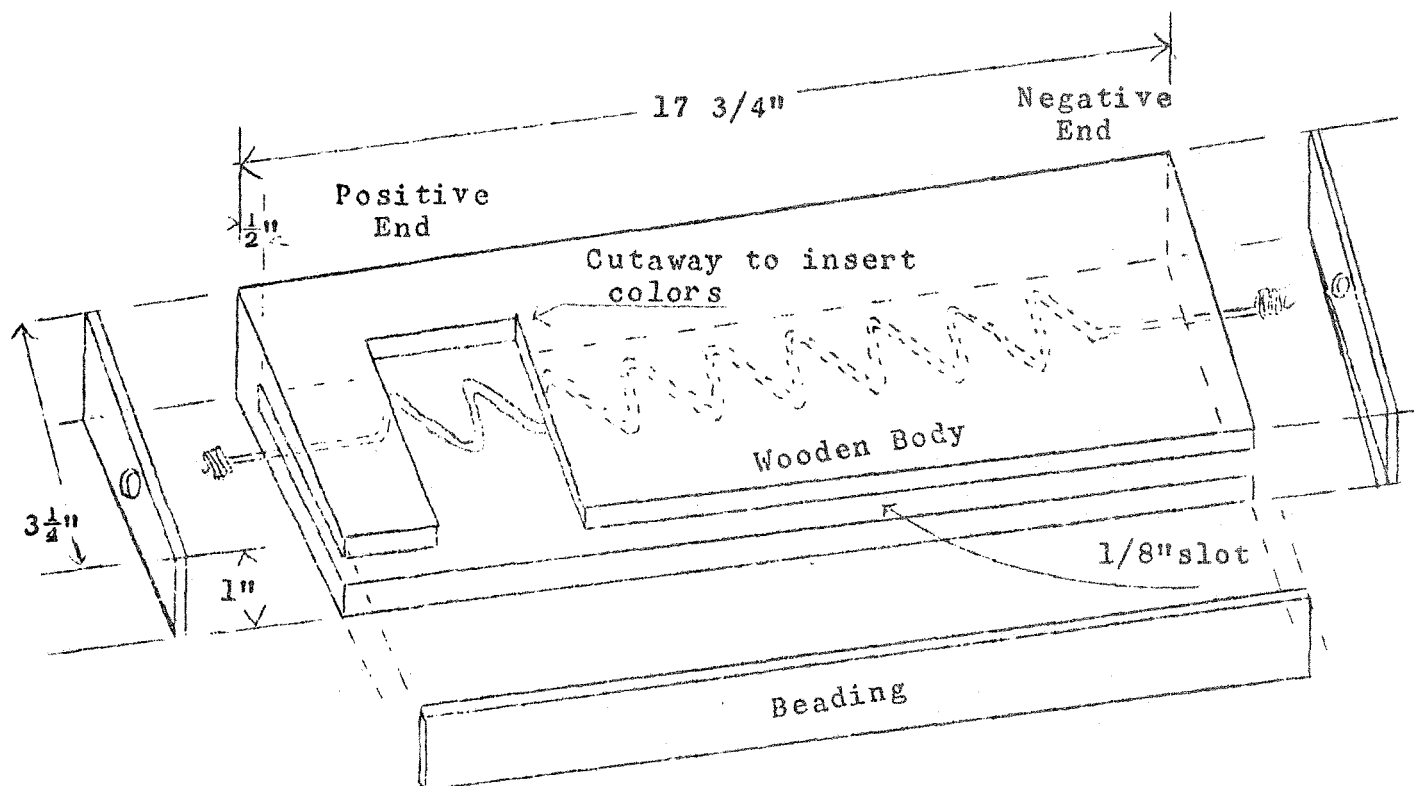

Wire can be formed on a jig made up to give 18 loops. Then lift off and insert in wooden body in the slot as shown. Wire at positive end twisted anti-clockwise to form a small coil. Wire at negative end similarly twisted but in clockwise direction. These small coils extend beyond ends of body and the beading pieces are then nailed in position with panel pins. Holes in end beading pieces permit them to pass over small coils. Wire is 8 ft. 4 1/4 in. long, of 16 or 18 S.W.G. copper wire. (For more information on Brownlee's article, originally in the April-May 1964 Journal, write to 37 Inglewood St., Glen Innes, Auckland.)

AN INITIATE AT WORK

From Fritz Peters' "Gurdjieff Remembered"
The famous pagan magician demonstrates
masterful handling of an Encounter Group
in New York City of the 1930s.

"After seeing Mr. Gurdjieff in Chicago in 1932, there was an interval of about two years which I did not see him again. I had moved to New York in the fall of 1933, and one Saturday afternoon when I came home from work my landlord told me that a very strange man, with a heavy, foreign accent had come to see me and wanted me to get in touch with him. The landlord, however, had not been able to understand him, did not know his name, and only knew that whoever he was, he was living at the Henry Hudson Hotel. I thought of Gurdjieff at once, although it was difficult to believe that he had gone to the trouble of finding my address and then coming to search for me in person. I went to the hotel immediately and, as I had expected, found him there.

"When I got to his apartment in the hotel, he told me that he had tried to find me earlier in the day, but that now it was too late and that he had no further need of -- or use for -- me. There was no affection in his greeting and he merely looked bored and very tired. In spite of this, and because I was glad to see him and worried about his great weariness, I did not leave but reminded him that he had once told me that 'it was never too late to make reparations in life', and that while I was sorry not to have been home earlier, there was surely something I could do now that I had arrived.

"He looked at me with a tired smile and said that perhaps there was something I could do. He led me into the kitchen, indicated an enormous pile of dirty dishes and said they needed to be washed; he then pointed to another equally enormous pile of vegetables and said they needed to be prepared for a dinner he was going to give that evening. After showing these to me, he asked me if I had time to help him. When I assured him that I did, he told me to wash the dishes first and then prepare the vegetables. Before leaving the kitchen, to rest, he said that he hoped he would be able to count on me to finish both jobs -- otherwise he would not be able to rest properly. I told him not to worry and went to work on the dishes. He watched me for a few minutes and then said that several people had promised to help him that day but that there were no members of the New York group who were able to keep their promises. I told him that he had better rest while he had the opportunity and not waste his time talking to me, and he laughed and left the kitchen.

"I was finished with my work when he returned and he was very pleased. He then began to cook the evening meal and told me to set the

table for fifteen people, adding that some very important people -- important for his work -- were coming to dinner and that when the food was in the oven he would need me to help him by giving him an English lesson as it was essential that he talk to these people in a certain way -- in a language that they would understand correctly.

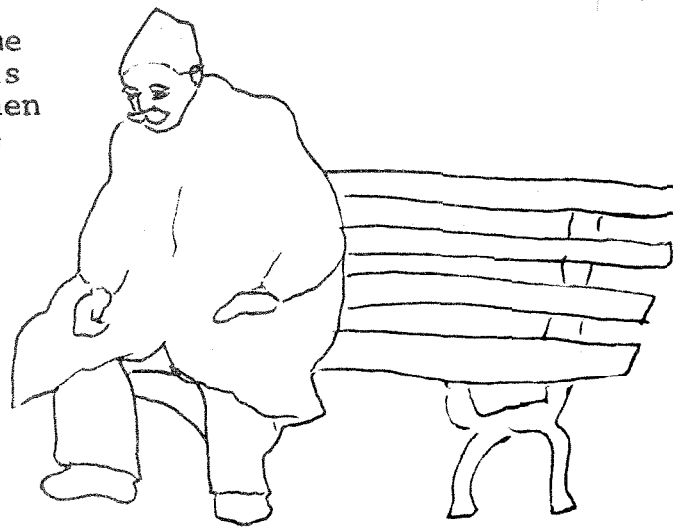

"When we had finished our work, he sat down at the table, told me to sit next to him and then began asking me questions about the English language. It turned out that he wanted to learn, before the guests arrived, all the words for the various parts and functions of the body 'that were not in the dictionary'. We spent perhaps two hours repeating every four-letter word that I knew, plus every obscene phrase I could think of. By about seven o'clock he felt that he was reasonably proficient with our 'slang' vocabulary which he, apparently, needed for his dinner.

"Inevitably, I began to wonder what sort of people would be coming to dinner? At the conclusion of this 'lesson' he told me that it was for that lesson that he had been trying to find me, because I was the first person who, some years before in Chicago, had given him the real flavor and meaning of the words 'phony' and 'leery'; it seems that these words, in the interim, had become very useful in his conversations with his American students. 'These very good words,' he said, 'raw. . . like your America.'

"When the guests did arrive, they turned out to be a group of well-dressed, well-mannered New Yorkers, and, since Gurdjieff had gone to 'prepare' himself for dinner, I greeted them and, according to his precise instructions, served them drinks."

It is safe to say that Gurdjieff was in the room during the cocktail preliminaries -- from an occult point of view -- making a telepathic survey of the minds and emotions of his guests before meeting them physically.

"He did not appear until most of them had been there for about half an hour, and when he greeted them, he was very apologetic for the delay and extremely effusive about how beautiful the ladies looked and how much they were all honouring him by consenting to be the guests of a poor, humble man like himself. I was actually embarrassed by what seemed to me a very crude form of flattery and by his presentation of himself as an unworthy and very obsequious host. But, to my surprise, it seemed to work. By the time they were seated at the dinner table, all the guests were in a very mellow mood (they had had only one drink so it was not due to liquor) and they began,

in a somewhat jocular and superior way, to ask him questions about his work and his reasons for coming to America. The general tone of the questions was bored -- many of the people present were reporters or journalists -- and they behaved as if they were carrying out an assignment to interview some crank. I could already see them making mental notes and could imagine the sort of 'funny' interview or feature story they might write. After some questioning by this group I noticed that Gurdjieff's voice changed in tone, and as I watched him he gave me a sudden, sly wink.

PREPARING THE SHEEP FOR SHEARING

"He then proceeded to tell them that since they were all very superior people that they of course knew -- since a simple person like himself knew it, then obviously they did -- that humanity in general was in a very sad state and could only be considered as having degenerated into real waste matter, or to use a term that was familiar to all of them, pure 'shit'. And that this transformation of humankind into something worthless was especially apparent in America -- which was why he had come here to observe it.

"He went on to say that the main cause of this sad state of affairs was that people -- especially Americans -- were never motivated by intelligence or good feelings, but only by the needs -- usually dirty -- of their genital organs, using of course (as he talked) only the four-letter words which he had practised with me earlier."

Here in New York City, in 1933, this Tibetan Tulku was practicing Gestalt therapy before its founders-to-be were even out of college! They were being treated to a "verbal exploration of self and others" by an old master at the art.

"He indicated one very well-dressed, handsome woman, complimented her on her coiffure, her dress, her perfume, etc., and then said that while she, of course, might not want everyone to know her motives or her desires, he and she could be honest with each other -- that her reasons for turning herself out so elaborately were because she had a strong sexual urge (as he put it 'wish to fuck') for some particular person and was so tormented by it that she was using every means and every wile she could think of in order to get that person into a bed with her. He said that her urge was particularly, especially strong because she had a very fertile imagination and could already picture herself performing various sexual acts with this man -- 'such as, how you say in English? Sixty-nine?' -- so that, aided by her imagination, she was now at the point where she would do anything to achieve her aim.

"While the company was somewhat startled with this dissertation (not to say 'titillated'), before anyone had time to react, he began a description of his own sexual abilities and of highly imaginative mind, and described himself as capable of sustained sexual acts of incredible variety -- such as even the lady in question would not be

able to imagine.

"He then launched into a detailed description of the sexual habits of various races and nations, during the course of which he pointed out that while the French had a world-wide reputation for amorous prowess, it would be well for the people present to make a note of the fact that those highly civilized French used such words as Mama and Mimi to describe some of their unnatural and perverted sexual practices. He added, however, that in all justice to the French they were, in reality, very moral people and sexually misunderstood and misrepresented.

READY NOW FOR THE ENCOUNTER SESSION

"The guests had all been drinking heavily during dinner -- good old Armagnac, as always -- and after about two hours of unadulterated four-letter word conversation, their behaviour became completely uninhibited. Whether they all had come to believe and accept that they had been invited to an orgy, for for whatever reasons, an orgy -- or the beginning of one -- was the result. Gurdjieff egged them on by giving them elaborate descriptions of the male and female organs, and of some imaginative uses for them, and finally most of the guests were physically entangled in groups in various rooms of the apartment, and in various states of undress. The handsome lady had maneuvered herself into a small bar with Gurdjieff and was busily making 'passes' of a rather inventive nature, at him.

"As for me, I was cornered in the kitchen by an overblown, attractive lady who told me that she was outraged that Gurdjieff should use such words in my presence -- I did not look more than about seventeen. I explained, quite honestly, that I had taught the words to him, all of them! She found this suddenly hilarious and promptly made a pass at me. I backed away and told her that, unfortunately, I had to do the dishes. Rebuffed, she glared at me, called me various dirty names and said that the only reason I had turned her down was because I was 'that dirty old man's little faggot', and only wanted him to 'screw' me. I was somewhat startled at this, but remembered Gurdjieff's reputation for sexual depravity and made no response.

"While the other guests were still hard at it, Gurdjieff suddenly disentangled himself from the lady and told them all, in loud, stentorian tones, that they had already confirmed his observations of the decadence of the Americans and that they need no longer demonstrate for him. He pointed at various individuals, mocked their behaviour and then told them that if they were, thanks to him, now partly conscious of what sort of people they really were, it was important lesson for them. He said that he deserved to be paid for this lesson and that he would gladly accept cheques and cash from them as they left the apartment. I was not greatly surprised, knowing him and having watched the performance of the evening, to find that he had collected several thousand dollars. I was even less surprised when one man told me -- as it were 'man to man' -- that Gurdjieff, posing as a philosopher, had the best ideas about sex, and the safest 'cover' for his orgies, of anyone he had ever known.

TRUTH, NOT OPINION

"When everyone had left, I finished washing the dishes, and to my surprise Gurdjieff came into the kitchen to dry them and put them away. He asked me how I had enjoyed the evening and I said, youthfully and righteously, that I was disgusted. I also told him about my encounter with the lady in the kitchen and her description of my relation with him. He shrugged his shoulders and said that in such cases the facts were what constituted the truth and that I should never worry about opinions.

"Then he laughed and gave me a piercing look. 'Is fine feeling you have -- this disgust. But now is necessary ask yourself one question. With who you disgusted?'"

"When I was ready to leave the apartment, he stopped me and referred again to my experience with the lady. 'Such lady have in self many homosexual tendencies, one reason she pick on you -- young-looking boy, seem almost like girl to her. Not worry about this thing she say to you. Gossip about sex only give reputation for sexiness in your country, so not important, maybe even feather in hat, as you say. Some you will learn much more about sex, but this you can learn by self, not from me.'"

As a boy, Fritz Peters was sent to board with Gurdjieff at the Priory in France in the 1920s; so the relationship between the two was more that of father and son, rather than guru and chela. Thus the uniquely personal point of view in "Gurdjieff Remembered", published by Victor Gollancz, London, 1965, and Samuel Weiser, 734 Broadway, New York 10003, 1971, for about \$3.00. If this side of Gurdjieff's many-faceted nature was known to his star pupil, P.D. Ouspensky, there is no hint of it in Ouspensky's writings. So Gurdjieff devotees should have some lively times trying to figure out whether the 1933 Gurdjieff of New York City was a deterioration from the 1915 Gurdjieff of Moscow and St. Petersburg; or whether his image as a teacher was mocked up to suit the limitations and understanding -- and demands or desires -- of a particular pupil or group.

* * *

MOST UFO SIGHTINGS GO UNREPORTED

"If you have seen an Unidentified Flying Object (UFO) at some time in your life and not reported it because of fear of ridicule, you needn't be ashamed. There are nearly five million Americans in the same position as you, according to a Gallup poll. And virtually all of them are respectable, middle-class people with their minds firmly rooted in reality.

"A Northwestern University graduate student, Michael Bauer, has done research which concludes that most sighted UFOs are never reported simply for the reason that the sighters think nobody will believe them. . . ."

The National "Insider", May 1973

INTERSTELLAR COMMUNICATIONS SIGNALS

By L.G. Lawrence, Field Manager
Ecola Institute

The possibility of life beyond Earth tends to evoke partisan emotions denoting two extremes (1) that life is unique to Earth, and (2) that it is ubiquitous and abundant throughout the universe. Hints about life elsewhere have been vague, including "organised elements" in meteorites, Martian infra-red spectra implying organic molecules, and the rare non-random radio signals whose reception was claimed by Tesla and Marconi. Yet a psychological readiness to accept extraterrestrial life has emerged to a most profound degree.

Divorced from its science-fiction background by Project Osma in the early 1960s, the topic is now formally called "communication with extraterrestrial intelligences" (acronym CETI). It was the subject of a top-level international conference held in September 1971 at the Byurakan Astrophysical Observatory in Soviet Armenia. The meeting was sponsored by the United States and Soviet Academies of Science. Similar interests prevail in private study groups both here and abroad.

Such programs must be welcomed in behalf of all mankind. For interstellar communication with other, highly advanced cultures might well determine human progress and survival. Thus, by inference, CETI emerges not only as the greatest adventure of mankind, but also poses a colossal challenge to systems engineering.

It remains an unfortunate fact that the majority of ambitious CETI programs continue to be aligned with the somewhat obsolete theories and hardware of radio astronomy. This is a serious drawback for several reasons: (1) local inadequacies in interstellar communications technology and humanness are imposed upon a given extraterrestrial society (prompting it to lose interest in us), and (2) we must be aware of the pre-eminent possibility that Type II or III civilizations -- whose worlds were old when Earth was young -- no longer employ electromagnetics-based communication technology due to obsolescence. The latter assumption is defensibly supported by the fact that terrestrial radio astronomy, in its 40-year-long history as an electronics-based science, has failed to detect intelligent, non-Gaussian signals from deep space.

A somewhat better, more promising outlook has emerged as the result of experimental data obtained by our Institute. The inference has been drawn that interstellar communications signals, as presumably

are interchanged between peerage groups, are of a biological -- rather than electromagnetic -- nature. If verification tests continue to be affirmative, it will explain the aforementioned failure of traditional radio astronomy.

COMMUNICATION BY ACCIDENT

As one frequently encounters in exploratory research, our CETI-type data was incidental to other work and not sought for.

We operate a mobile field laboratory. One of our objectives is the development of non-polluting electronic alternatives to chemical fertilizers and pesticides used in agriculture. Special investigations are directed at behaviorial plant electrophysiology and bioelectric phenomena associated therewith. Viable organic transducers have been evolved, profiles of which were given in (1) ELECTRONICS WORLD, New York, October 1969, pp. 25-28, and in (2) ELECTRICAL REVIEW, London, June 2, 1972, pp. 780-81. Composite techniques have been adapted for field research in remote biological sensing (acronym: RBS), which allowed discovery of the following phenomena:

On October 29, 1971, 20:30 PDT, while conducting exploratory RBS experiments in Riverside County, California, our field instrumentation's organic transducer complex intercepted a train of apparently intelligent communications signals (tight spacing and discrete pulse intervals) while accidentally allowed to remain pointed at the constellation Ursa Major during a short rest period. The phenomenon prevailed for somewhat over 33 minutes, approximately 30 minutes of which were recorded on tape when the audio monitor drew our attention.

A somewhat similar phenomenon was observed on April 10, 1972, 22:30 PDT, while conducting experiments in the Mojave Desert, California. Other, fragmentary interceptions have been made in the interim. The apparent signals, aside of seemingly growing weaker, appear to be transmitted at great intervals ranging from weeks to months, possibly years. A faint, coherent, binary-type phenomenon was noted during aural monitoring using equipment such as shown in the accompanying illustration. Intervals between rapid series of pulse trains ranged from approximately 3 to 10 minutes. It is likely that other phenomena have escaped detection, since lack of special facilities and resources precludes routine monitoring at this time.

Because our equipment is impervious to electromagnetic radiation and found free of internal anomalies, the tentative conclusion of biological-type interstellar communications signals has emerged. We also entertain the possibility of an emergency transmission (here directed at peerage societies only), since relatively large power levels of given makeup are required to overcome bioelectric impedances and galvanic network losses inherent in our developmental instrumentation. A two-way transceiving capability has not yet been achieved.

Data contained in our October '71 tape was accrued via analog DC-to-AC conversion techniques. Here, fluctuating DC signals, as generated by organic semi-conductors in the transducer complex during signal incidence, are made available for direct audio recording by changing DC products into variable-pitch audio patterns. As is customary in analytical telemetry, a local pilot tone was automatically injected into the tape for detecting mechanical tape-speed variations and/or electronic malfunctions, if any. Provisions have been made for synchronous electromagnetic interference monitoring. (See illustration)

As a mere audio presentation, the instrumentation tape is unpleasant to listen to. However, as many reviewers concede, a fascinating degree of enchantment tends to emerge after the tape has been played back three or more times, typically over a period of weeks. We ascribe this to psycho-physical adaptation, since individual acuities to the dominant pilot or control tone tend to be attenuated when playbacks are repeated. The audio-frequency envelope peaks out at approximately 5,000 Hz and is fairly uniform. The tape contains a short, incremental series of deep, harmonious oscillations resembling nonsense chatter or background modulations. An intelligent character of the overall pulse train is applied by discrete spacing patterns, apparent repetitions of sequences, and highly attenuated Gaussian noise. Arrangements are being made for computer analysis.

Coding formats and nature of signal-emanating domain remain unknown. Reports of similar observations made elsewhere are being solicited.

To preserve physical evidence of what might well be an extremely important historical event for generations yet to be born, a copy of the October '71 tape has been deposited with the scientific archives of the Smithsonian Institution, Washington, D.C.

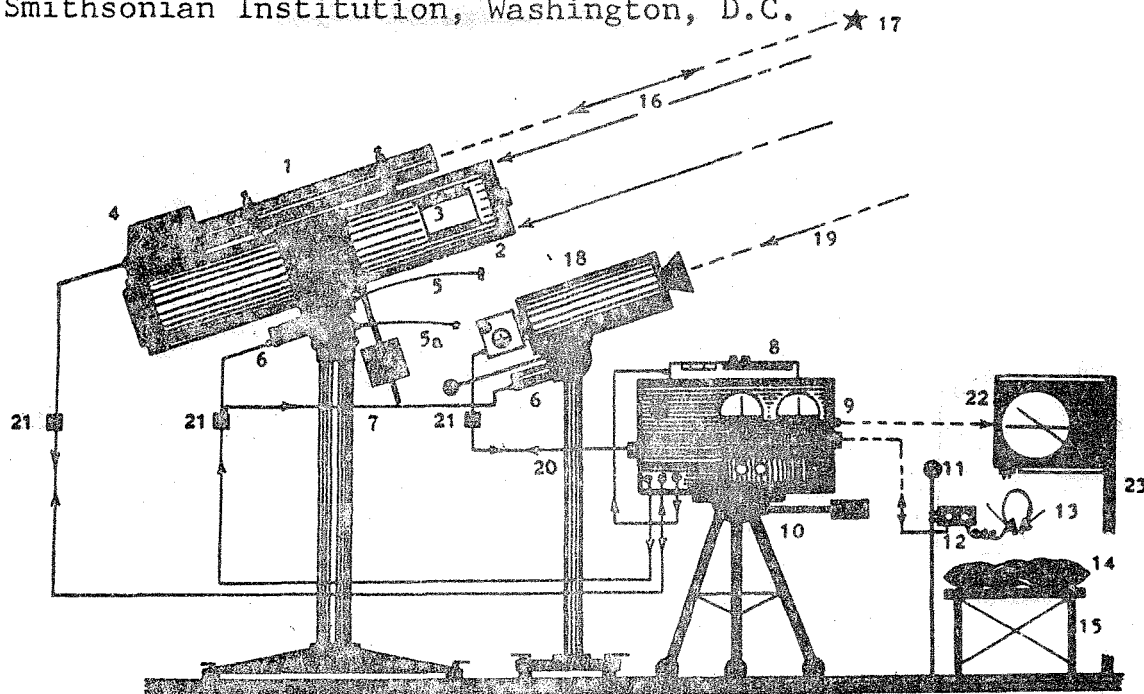

- Fig. 1 -

THE BIODYNAMIC FIELD STATION

A biodynamic field station designed for interstellar signal interception is shown at bottom of previous page. Principal components are: Organic transducers housed in the TRANSDUCER CHAMBER (4), optical sector recording aids comprised of a NEWTONIAN TELESCOPE (2) and CAMERA (3), excitation and converter systems contained in the ELECTRONICS (9) package, an ELECTROMAGNETIC INTERFERENCE MONITOR (18), a clock-driven SYNCHRONOUS STAR MAP (22) for noting coordination of signal sources, and the OBSERVER'S NIGHT COT (15).

Legend:

- | | |
|-----------------------------|--|
| 1. Faraday Tube | 13. Headphones |
| 2. Newtonian Telescope | 14. Headrest w/Pillow |
| 3. Camera | 15. Observer's Night Cot |
| 4. Transducer Chamber | 16. Optical/Biodynamic Target Axes |
| 5, 5a. Slow-motion Controls | 17. Celestial Object/Domain |
| 6. Ascension Drive(s) | 18. Electromagnetic Interference Monitor |
| 7. Mounting | 19. RF Incidence |
| 8. Field Recorder | 20. Mounting |
| 9. Electronics | 21. Connectors |
| 10. Tripod | 22. Synchronous Star Map w/Illuminator |
| 11. Ground Spike | 23. Mounting |
| 12. Remote Controls | |

* * *

We were on the same lecture program with Lawrence and had the opportunity to see and hear his illustrated talk on Interstellar Communication. This was at Esther Ellsworth's Understandorama at Claremont, California, May 6, 1973. He had the Organic Transducer with him, set up backstage, and showed us a green plant leaf pressed between two electrodes. We could hear the 'pilot tone' on the audio equipment. A threat was made to the living leaf by bringing a lighted cigarette close to it. The change in the pilot tone was easily heard. Attempts to reproduce this Backster Effect by mental means only -- that is just thinking of harming the leaf with a lighted cigarette -- were not quite so successful, though some plant response was heard.

Obviously this man is a competent technician, with tremendous capability for creating and adapting research equipment to his needs. He appears to be a true scientist, following the search for Truth wherever it might lead, regardless of what his preconceived ideas of life might be, here or in space! An example of this was his readiness to go ghost-chasing with his Organic Transducer in a haunted house in San Bernardino. The wait for any phenomena to manifest was a long one, so long that Lawrence fell asleep, as he put it. Thus the scientist became a passive receiver along with his equipment. Only then of course could the spook manifest! The shrill increase in pilot tone signalled the presence of the intruder -- who was also in Lawrence's aura!! He didn't say this on the lecture stand but in

private conversation with us afterward he admitted that it took him a month to get rid of his unwelcome "eating companion". This was a powerful lesson in occult science, one we all have to learn somewhere along the line of evolution.

You can get in touch with Lawrence directly at his Ecola Institute, PO Box 3284, San Bernardino, Cal. 92413. He also teaches the science of Interstellar Communication at the Anchor College of Truth, 1775 Devore Road, San Bernardino, California 92407. Weekend classes in parapsychology, metaphysics and comparative religions are also being offered there throughout the summer. The College is to the left off Highway 395 on Devore Road, a couple miles north of San Bernardino.

Below is a picture of Lawrence's new Astrobiological research instrument, a radiotelescope with biological signal sensors, mounted on a pan-azimuth yoke assembly, "to scan the galaxy on a 24-hour basis".

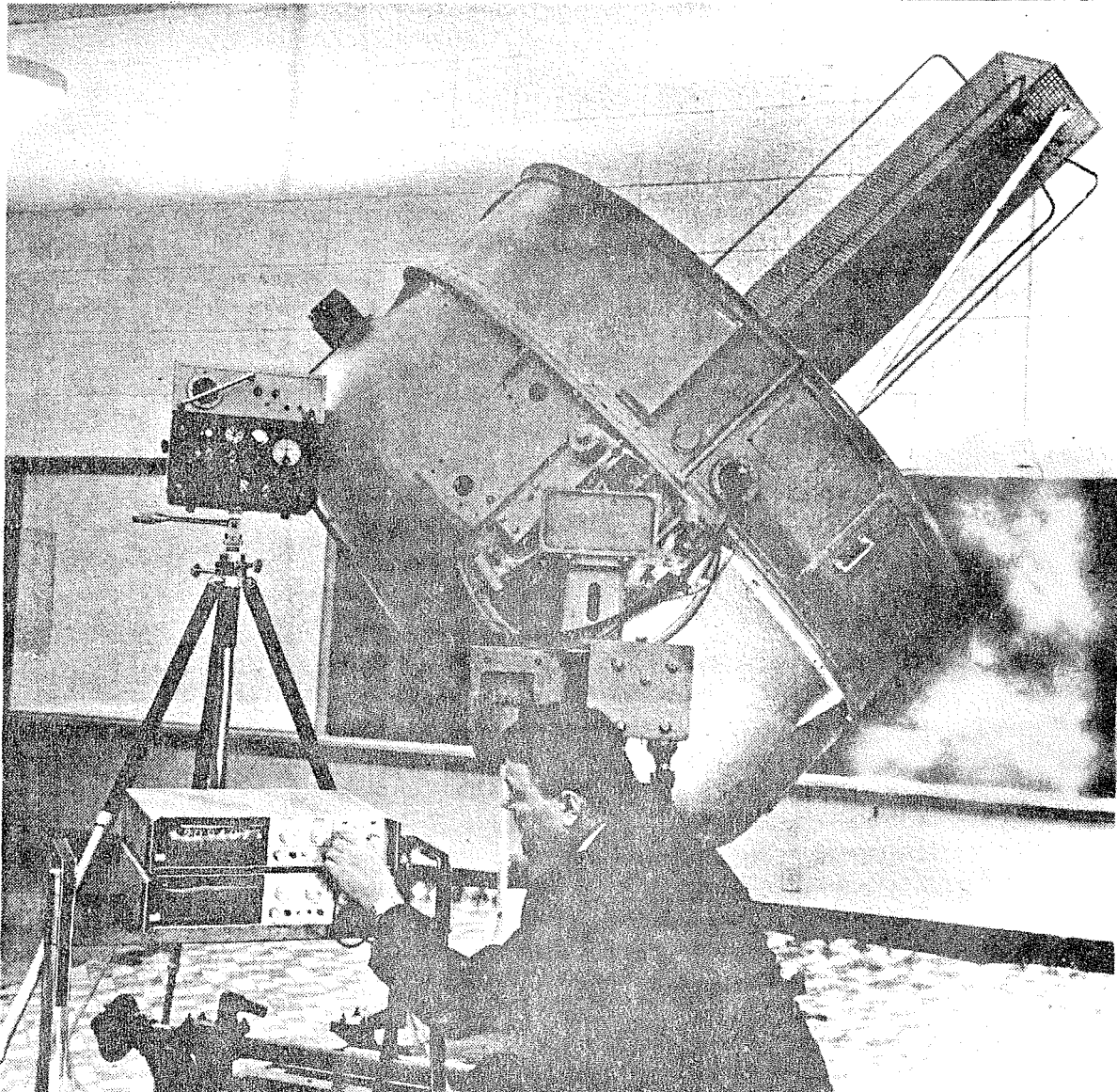

THE TRUTH FINDERS

The Secret Treasure Of The Albigenses
By N.Z. Correspondent of the Inner Kingdom

It is known that in the Middle Ages the Albigenses and allied tribes of Southern France possessed two secrets so precious that they meant more than life itself to them.

The first was two-fold, and the first part of this two-fold secret is gradually dawning upon mankind today. As the Father dwells in the Son and works through Him, so He dwells in us and will work through us in the power of Christ, if we ask Him to do so. Thus we become "Sons of God" as promised; for, as impressed upon the "Man From Texas" by the Angel related in the book RADIX, between God and man there never has been separation as is taught by the Churches; for always He has dwelt in mankind, limited only by human thought.

"Whither shall I go from Thy spirit? or whither shall I flee from Thy presence?" Psalms 139:7. It is through the Spirit of Christ within that we become aware and alight with the knowledge that the Father lives in us and thus we learn the first part of the first secret.

When the Albigenses realised they were the temple of the living God, they worshipped Him within, and His love flowed out of them to inspire love in others. This is the second part of the first secret and its teaching is the practice of Love in the world. When we also worship Him within and live accordingly, His love flows out of us without effort to others in this way. Having found this Truth we need no longer spend our time in seeking it, but bring it into action by stilling our minds and resting them upon Him. As we do this, the brighter and brighter He becomes in order, through us, to build His Kingdom here upon earth around the nucleus, hub or Headstone of Christ Jesus; for "Except the Lord build the house they labour in vain that build it." Psalms 127:1.

Before Church Reformer John Huss of Bohemia went to the stake in 1415, he declared, "I am certain that the image of Christ will never be effaced. They (the Roman Catholic priests) had tried to destroy it, but it will be imprinted anew in the hearts of men." Fortunately for us, we are not only incarnate on earth in the very time foreseen by Huss, but empowered through baptism by the Holy Spirit to bring his words into effect. The formula is this:

When, like the Albigenses, we realise that God actually dwells within us, we shall immediately help Him set the building work in

motion by worshipping Him and loving Him "with all our hearts, with all our souls, with all our strength and with all our minds," which is most effective in enabling Him to use us for the building work at third dimensional level. Then He will expand and magnify Himself in us and beyond us; for this is the purpose and the Plan throughout the Ages; when the Son of Man will come into His own at last; and the power of the Usurper over the world will be broken. "For behold, darkness shall cover the earth, and gross darkness the people; but the Lord shall arise upon thee and His glory shall be seen upon thee." Isaiah 60:2.

Thus free from a half-conscious or dead condition we shall "come alive" and be so filled with His love and understanding that they will overflow on to all His creatures, human or otherwise, who can respond; and from them to us, hastening the practice of Love in the world, which is to become universal rather than the exception as at present. Therefore the sooner we come awake and do our part in the Plan the sooner the Kingdom will come; for who does not long for the reign of Love upon earth by Him whose sufferings have raised us up?

This, then, is the Day of Opportunity for all to become alight with the grace of Christ; for a purpose so blessed and majestic that it means more than life itself to those who can respond. It is, in fact, the answer to the prayers of the Albigenses, of Huss, of Jerome and multitudes of other martyrs as they died at the stake for their endeavours to undertake the selfsame building work we now have the opportunity of helping God to do. It was part of their treasure and their joy, and is the blueprint for the coming way of life, so simple and so satisfying that a little child can understand it. If we truly obey the First Commandment, then God is able to work His will. This Commandment, as the Albigenses found, is the key to the Door of Paradise, in which they walked while still on earth; but we know, as they had apparently not discovered, that Christ Jesus Himself is that Door, by which those who love and serve Him "shall go in and out, and find pasture". St. John 10:9.

* * *

The history of the Albigenses has been obscured by time and by the book-burning proclivities of the right-wing fanatics of the Roman Catholic Church; however, if you are interested in looking into the story of this early Protestant sect, try to obtain a copy of Zoe Oldenburg's "The Massacre at Mont Segur". There is no doubt that these Light-oriented martyrs of the 13th Century, both in and out of the flesh, are helping hold back the tides of Evil which threaten to engulf the earth at this time. One of the stronger of these out of the recent past is Sir Arthur Conan Doyle. The book of his communications after his transition in 1930, "The Return of Arthur Conan Doyle" is a revelation of the work of the Inner Plane Adepts in preparing us for the coming changes and even helping us to direct the Aquarian Age rays in accomplishing those changes.

THE KINSHIP OF RELIGION AND SCIENCE (cont.) Steps 10 and 15. Robert W. Wilson.
Awareness, Prayers, Dreams, Turning Point.

Man can sense only a few of the vibrations of the Universe—sounds from 16 per second to 32,000, varying with individuals—light from infra-red (which we feel as heat) up to but not including ultra-violet. But dogs respond to whistles too shrill for human ears, some insects react to ultra-violet rays. Under special conditions the blue corona around a live wire becomes visible. That these human faculties may be extended is shown by the sensitivity of skilled musicians to tone gradations imperceptible to the ordinary ear, and of specialists to fine differences in color—Luther Burbank could grade daisies, all white to the untrained eye, and by breeding from what he saw as the pinkest produce strong pinks in a few generations.

It is commonplace to expand the range of hearing by the telephone, of the eye by radar, but this type of thing, wonderful when one thinks about it, is comparable in principle to extending the arm's reach by a stick.

Entirely different types of awareness have been recorded from ancient times to now, usually when conditions of strain, eagerness, or religious exercises, have raised the personal vibrations. Two broad classes are noted—where an angel or devil is perceived, and where there is none. Both classes are recorded from Bible times to the extensive modern literature such as the carefully screened transactions of the Society for Psychical Research. See also William James, "The Varieties of Religious Experience", The Modern Library Series, N.Y.

Among the first class are: The famous episode of Martin Luther throwing his inkpot at the Devil, the Angel of Mons in 1914 when the Allied forces were well-nigh destroyed, the Virgin of Fatima, Portugal 1941, (more remote) Gabriel and Mary, Luke 1:13-21, Jacob wrestling with the Angel, Genesis 32:24-29.

Swedenborg was the leading modern example of the second class; he maintained that faith is impossible where reason is ignored (many disagree with this position) and he had many things shown and explained to him while in full waking consciousness—the best-known being his vision of the great Stockholm fire of July 19, 1759 while he was in Gothenburg, 300 miles distant. His account of the modus operandi is found in his "Heaven and Hell", Swedenborg Foundation, Inc., 150 Fifth Avenue, New York. Briefly, although the perception is spiritual and inward, it seems to be seen or heard. See also Daniel 8:1-15, "a vision appeared unto me" of the future of the Babylonian Empire, followed by Alexander, and so on. Not until verse 15 does Gabriel come to explain it. Jesus had such perceptions; seeing from afar the condition of the centurion's servant, John 11:14, and of Lazarus, Matthew 8:13.

Visual inspiration extends to things secular as well as religious, "for your Father knoweth ye have need of these things", Matthew 8:13. When research in organic chemistry was stuck in 1866 because nobody could find the structural formula of benzene, C_6H_6 , Kekulé, one of the greats in the organic field, said to his co-workers. "Let us dream; perhaps we shall find the truth." Accordingly he fell asleep and dreamed of "six carbon atoms arranged in a chain, like a group of dancing imps, $-C-C-C-C-C-C-$, [each with a dependent hydrogen atom] and then

Awareness, Prayers, Turning Point (cont.)

saw the imps at the imps at the ends join hands in a ring dance, awoke, Kekulé realized that this ring might truly be the structure of benzene. . ." (Organic Chemistry Simplified, Rudolph Macy, Ph.D., Chemical Publishing Co., Brooklyn, N.Y., 1944, p. 157.) This knowledge, only theoretical at the time, started fruitful research in petroleum, rubber, dyes, and other lines. Two generations later the electron microscope confirmed the theory by picture. Similarly, Elias Howe, stymied in trying to invent a sewing machine, had a dream starting him in the direction of putting the eye at the needle point.

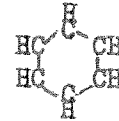

When he

These are instances, contrary to the belittling attitude of skeptics, showing that men of outstanding accomplishment, whose judgement and training won them renown, are "otherwise sensible" when they conclude that supernatural phenomena are not delusions. Swedenborg filled high positions in the Swedish Government in iron mining and finance when the economy was largely based on iron production, he was active in politics, and among lesser practicalities improved stoves and ear trumpets. Sir Oliver Lodge, whose attainments in wireless telegraphy and electronic research were highly recognized, also believed in the psychic. Nor should differences, or even contradictions, in descriptions of non-earthly scenes imply falsity—our Father's house holds many rooms—and even in the earthly it is seldom two accounts of the same scene or event agree.

Angels or demons may be reached by needs, strong feelings, troubles, prayers, or whatever, they are responsive to minor as well as major situations, and the replies may be very various—"hunches", flashes of insight, feelings of unseen presences, dreams, voices. But the student is warned not to take every unusual experience or intuitive decision as a leading from Above. Far from it: like children learning to walk, we develop by successes and failures—help is given only when really needed. "Take it to the Lord in prayer" must be followed judiciously; we must not become spiritual cry-babies, nor must we take our own self-deceptive selfishness as the answer.

Another danger is that blind spiritual receptivity may open one to what modern psychology, although arbitrarily denying Biblical "evil spirits", nevertheless recognizes as "negative aspects of the collective sub-conscious". So, even in seeking spiritual help, "with all thy getting, get understanding", Proverbs 4:7. Discrimination as to seeking help strengthens with practice—as we gain in self-dependence, help really needed is more readily accorded. The Agents—usually Angels but sometimes higher as explained in Step 3—are on the lookout for humans who will be worth helping; those whose own attitude toward life is co-operative.

Because the Divine Plan is cyclic—see Steps 2 and 3—all orders of Agents, including Man, by whom the Creator built and is building the Universe, are being trained for still higher work, but because all are endowed with Free Will, all orders are looking for those further down who are willing to be trained to help, somewhat as at our own level we look for animals that can be tamed rather than those savage or obstinate. (This is only an analogy, because animals, lacking the Divine Spark of true reason, have no real Free Will.)

THE KINSHIP OF RELIGION AND SCIENCE. Steps 10 and 15 (cont.) Robert W. Wilson.
Awareness, Prayers, Turning Point (cont.)

Misuse of Free Will explains the Fall of the Angels, Revelation 12:7, with resulting disharmony to everything further down—the Fall of Man, Genesis 2:17 and chapter 3, noxious creatures and evil plants. Such questions as why God "did with Paradise devise the snake", Rubaiyat of Omar Khayyam 81, 4th ed., can be answered partly to a Wise Parent allowing maturing children to make their own mistakes to learn by them. It is somewhat as a boy old enough to have a dog must become responsible for its care even if the animal would be better off by the father's direct care.

Earth was intended to be a School, but its great cruelty and harshness, not intended by the Divine Plan was due to some mistakes by High Agents Who assisted Creation. For this reason, Divine Justice and Grace not requiring the Lower Orders to atke the full suffering resulting from the errors of the High, it will be possible for worthy individuals to escape even global-scale failure occurs. Although having to live with evil is contrary to Man's limited sense of Justice (see Step 7), we are obliged to live as best we can under the circumstances, with the remote solace that in the long run the struggle will make us stronger and wiser. But maybe it do us more harm than good! Justice truly Divine will not permit perdition to Man for the headstrong actions of even the Highest Agents.. the "elect" . . . whosoever shall do the will of God. . .", Matthew 24:31; Mark 3:35, will be saved from a general cataclysm through the Christ Spirit which "lighteth every man that cometh into the world", John 1:19, whether of the Christian or non-Christian religion, or even sincere persons of no organized faith. St. Paul tells, "work out your own salvation", Philippians 2:12, with help, as explained in Step 7, of what each human of good will feels to be the Christ Spirit.

SETTLE IT RIGHT

"Since nothing is settled until it is settled right, no matter how unlimited power a man may have, unless he exercises it fairly and justly, his actions will return to plague him."

Frank Vanderlip, quoted in the Forbes Scrapbook of Thoughts on the Business of Life, and from Dear Abby's column.

On one of Candidate Nixon's tours of Vietnam he stopped to chat with a colored soldier, of rather indefinite racial appearance.

"Good morning, are you from Indo-China?"

"No, suh," came back the indignant reply, "I'se from outdo' Mississippi!"

Adapted from Bennett Cerf's Laughter, Inc.

CLIPS, QUOTES & COMMENTS —

INTERPLANETARY COMMUNICATION

Back on page 10-11 of this issue we quote L.G. Lawrence as saying: "The inference is drawn that interstellar communications signals. . . are of a biological -- rather than electromagnetic -- nature. . . ." We are happy to say that we have found a forecast of this in the writings of Arthur Conan Doyle, through medium Grace Cooke, in 1932. This was 15 years before Flying Saucers became a household word!

"We are endeavoring to reach up to spheres of Cosmic Life which are above both the mental and celestial spheres we have described. From such spheres beings of highest spiritual consciousness ascend and descend, and are still able to maintain touch with mortal man. When a man by continual effort can get in touch with such beings he can receive clear communications from the inhabitants of other planets.

"Although man has long tried to invent an instrument in order to obtain such communications, he will eventually learn that only within his own inner self, interpreted by his own spiritual intelligence, can anything of the kind be established. First man must attain to brotherhood with his fellow-man in social and national life; and then to brotherhood between nations. Later will follow an interplanetary brotherhood which will someday become possible when the consciousness of humanity is raised."

The above from page 135 of "The Return Of Arthur Conan Doyle", edited by Ivan Cooke, The White Eagle Publishing Trust, Liss, Hampshire, England. Send for list and prices.

SUDDEN LOSS OF BINDING FORCE?

"F-4 Phantom Jet Wreckage Scatters Desert In Thursday Morning Mishap" is the headline of the March 8, 1973 "Imperial Valley Weekly", El Centro, California. "LCDR Don Bently, leader of the Navy's Blue Angels Flight Demonstration Team and his two wingmen all ejected to ground without major injury early Thursday morning, after an unexplained mishap at 7:10 a.m. caused their three F-4 Phantom jet aircraft to crash in the desert and explode in widely separated areas of the uninhabited practice range, 17 miles northwest of NAF El Centro. . . . The Blue Angels four-plane diamond had taken off for their usual early practice over the desert at about 6:50 a.m. They were reported as flying the back side of the trail loop, a maneuver with four aircraft flying in a line when the mishap occurred. The Team had been practicing for their nine-month show tour which was to have started Sunday at Yuma MCAS. . . . Cause of the accident has not been determined. . . ."

Nor is it likely to be; for the pilots were completely mystified by the breakup of their formation and their planes. The fourth plane

piloted by Marine CAPT Mike Murphy, landed safely. We think this is another example of a random vortex of reduced Binding Force in the earth's atmosphere. This one wandered into, or manifested briefly, in the desert air of the Blue Angel practice area.

An article on "Binding Forces, or Lack of Them" was in our Oct. 1963 Journal. It was by the late W.B. Smith, Director of the Ottawa Flying Saucer Club and government electrical engineer. Smith was informed by his UFO contacts that "our pilots flew around in complete disregard of the regions of Reduced Binding with which this planet is afflicted", and that these random, unsuspected vortexes of negative energy were the cause of the structural failure of some airplanes in mid-flight.

"The principle is quite simple," wrote Smith. "All matter is held together by the relative configurations of the three basic fields of nature, tempic (time), electric and magnetic. These configurations are characteristic of what we call the molecular structure, and the interactions of these fields is NOT linear. Therefore, since the fields interacting are the sums of the local fields, and the background fields, such interaction can be used to indicate certain characteristics of the background, through this very non-linearity."

Smith and his group were guided to construct a Binding Force Meter for detecting the existence of these electro-magnetic "sinks" in the earth's atmosphere. All the meter is, is a stretched nylon cord wrapped around a shaft with a pointer registering movement on a graded scale. Changes in the molecular structure of the nylon cord show as pointer movements, indicating that the meter is in a location where the Binding Force holding together the molecules of the cord has been reduced. Smith's UFO contact told him that every time we explode an atomic bomb in the earth's atmosphere -- such as the Chinese did in June and the French are now planning on doing in the South Pacific -- a hellish pair of vortices is produced to drift about .

"My colleagues and I have investigated the general areas through which aircraft have flown just prior to unexplained crashes," wrote Smith, "and we have found several regions of reduced binding, the meters showing several scale division changes. These regions seem to be roughly circular and about 1,000 feet in diameter, and probably extend upward quite a distance. A few have been detected by air when planes have flown through them, but fortunately in these cases the craft were strong enough to remain intact."

If you feel inclined to laugh at all this remember that the existence of Binding Force in the nucleus of an atom was discovered by atomic physicists in the 1920s and 30s. The fact that this Force could be suddenly released, to produce a tremendous atomic explosion, was established beyond all question by the explosion of the first atomic bomb at Alamogordo, New Mexico, July 16, 1945. The delicate balance of the protons and neutrons in the nuclei of the uranium atoms making

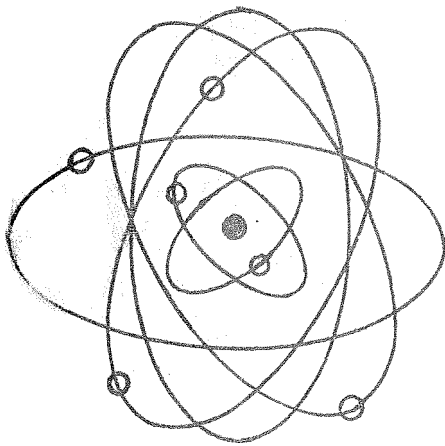

AT LEFT, a planetary model of a carbon atom (after Neils Bohr) showing the electron orbits and the nucleus at the center as a black dot. AT RIGHT, the model of a beryllium atom with four electrons and a nucleus of four protons and five neutrons, held together by a Binding Force which, when suddenly released, manifests as alpha, beta and gamma rays.

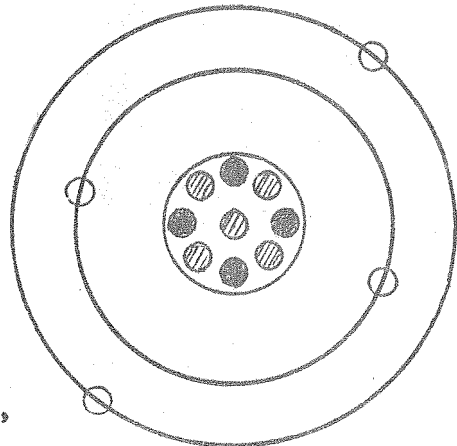

up the bomb was disturbed. In a stable atom, the mass of the nucleus must be less than the combined mass of the individual particles composing it. This is called the mass defect, I believe, and is a manifestation of the Law of the Conservation of Energy. This seems to indicate how the Logos holds the matter of His system together, by deliberately keeping it slightly off balance.

Atomic physicists have proven that if the mass of the nucleus is brought into balance with the combined mass of the protons and neutrons, the matter drifts apart, disintegrates. Here is a clue to the dematerialization and materialization phenomena of the seance room, where the release of the Binding Force energies are harmful to no one. But if an outside force is brought to bear on the nuclei of the atoms of the matter of a Hydrogen bomb, and the mass defect is suddenly reversed, the release of Binding Force energies is truly awesome.

And there is this lingering side effect in the earth's atmosphere, a pair of vortices in which the Binding Force is reduced. Smith writes: "it does appear that things are stronger in the northern latitudes than they are farther south, and certain areas seem to be permanently afflicted with reduced binding. We do not know if the regions of reduced binding move about or just fade away, but we do know that when we looked for several of them after three or four months we could find no trace of them."

THE SANTA CRUZ MYSTERY SPOT

One spot which seems to be "permanently afflicted" with slightly reduced binding is the Mystery Spot on a mountain slope a couple miles north of Santa Cruz, California. This permanent vortex is several hundred feet across and even the trees in and around it appear to lean out-of-plumb because of the pull. The present owner of the property discovered the spot because of its effect on his compass while making a survey. That space is warped there can be proven photographically by the apparent change in size of people in the vortex. Though there

is no feeling of an actual "grinding of bones" or other reduction or change in physical size, some dizziness and feelings of pressures on and within the system indicate that a definite, invisible force is at work and its effects linger in mind and emotions for hours afterward. We have constructed a crude Binding Force Meter after Smith's suggestions and intend to see if we can get reactions on it in the Santa Cruz vortex next time we are in the area.

Reprints of the four-page article by W.B. Smith on the Binding Forces or Lack of Them, from the October 1963 Journal, can be had from Headquarters here for 80¢.

"THE PSYCHIC WORLD OF DOC ANDERSON"

Appropriate to the preceding CQC item is the following quote from the new book by University of Tennessee psychologist A.L. Gary, being reviewed now in the "National Tattler" and sent in by Associate Ralph Martine: "Doc says he has never claimed to heal people; 'Healing is an act of God; all I do is pray,' he points out carefully.

"To illustrate what is meant by prayer, Doc will point to a picture on his office wall. It was taken, along with several others by John Goforth, a staff photographer with the Chattanooga News-Free Press. In the picture are Doc, James Burk, Sargent Osborne and Ernest Shindbaum, all watching a drinking glass disintegrate under the intense stare of Doc. Goforth took the picture with a high-speed lens and caught the glass just as it shattered -- the pieces suspended in mid-air.

"Doc says, 'I can concentrate my will and project my thoughts so intensely into a glass, for instance, that the force will break it. It might take 5 to 10 minutes, and the glass might rock and slide back and forth across the table several times, but that's what I mean by asking, believing, expecting and projecting.'"

If he only knew it, Doc Anderson, the Georgia prophet, has the potential of becoming another John Keely. So does anyone for that matter, if he or she is willing to practice the daily "five-finger exercises" of mind and emotions necessary to develop real skill in the magick of the Kabala.

GUARDIAN UFOS ON DUTY OVERHEAD

"A short time ago I was permitted to listen to a closed tape lecture through Mark Probert by the Yada di Shi'ite, given approximately five years ago when Mark was in this area. During the middle of the seance the Yada said that some time after 1975 there would be a nuclear war confrontation between Russia and China. While the people of this planet are watching and waiting for this atomic war to explode between the two Communist giants, it is then that the Flying Saucers and their occupants will appear. The Yada said that if the Russian and Chinese leaders will not heed the warning not to start a nuclear war between each other, the Space Beings then would use methods of

persuasion to change their minds. He did not go into detail as to the type or types of persuasion the Guardians would use on the Chinese and Russian leaders."

N.N., Cleveland, Ohio

This Associate attached to his letter a news clip from the Cleveland "Plain Dealer", Oct. 2, 1972, headed: "Soviets Now Enemy No. 1 to Chinese" and the Associated Press news story datelined Tokyo stated: "Communist China celebrated its 23rd anniversary yesterday with parties in parks, a scorching denunciation of the Soviet Union and a word that the way is open for 'friendly contacts' with Americans."



The Yada

Yes, the nuclear confrontation with Russia has forced the Chinese leaders to make a 180° change in policy. They realize they need friends and allies! The Russian leaders have reluctantly come to the same conclusion. Thus we have the unusual and encouraging spectacle of a great speed-up in international diplomacy. Even our President got into the act by suddenly switching off 25 years of anti-Communist hysteria and making a pilgrimage to Peking! The real reason appears to be the massive failure of our Holy War in Southeast Asia. For 1500 years the Church has survived with a policy of "if you cant beat 'em, join 'em" and Nixon's detentes with Russia and China appear to be a logical manifestation of that policy. Besides, there is money in it, billions of dollars, as in the sale of our wheat to Russia.

Turning a fast buck as an important part of international diplomacy indicates the low, material level at which our leaders are operating. This indicates there is no real peace in their hearts, only expediency; so greed for power and for money is bound to lead to a nuclear confrontation eventually; unless our daily prayers for international cooperation, brotherhood and goodwill really take effect.

We can be thankful that the Guardians are on duty overhead, watching, waiting, hoping the leaders of nations will do the right thing. If an all-out nuclear war really threatens, the massed appearance of great fleets of Flying Saucers over Peking and Moscow would be a desperate last resort on the part of the Guardians. It would bring a "loss of face" to Mao and Brezhnev and their henchmen. This would be even worse than the loss of credibility Nixon is suffering now because of Watergate! Inevitably, the Russian and Chinese governments would fall because the people would turn to the Visitors for the kind of leadership they are not getting from their fellow humans. I'm sure the Guardians dont want to be the cause of bloody revolutions here

on earth. I believe they would much prefer that we solve our own problems. That's what we're here for, to develop just that kind of maturity and responsibility.

THE FIFTH KINGDOM: WORLD DISCIPLESHIP

In every land, across national boundaries, borderland researchers are becoming aware of each other. They are linking up, mentally and emotionally if not physically, in an international network whose subtle influence is counterbalancing the fear, hatred, bigotry and prejudice of the small-minded and the socially immature.

For billions of years we have had Four Kingdoms on this planet: The Mineral Kingdom, the Vegetable Kingdom, the Animal Kingdom, the Human Kingdom. Now Aquarian Age influences are adding a Fifth Kingdom, a world-wide discipleship of advanced humans, older souls, who are ready, willing and able to live by the Christ-principle of Brotherhood. It is only this kind of unity, or unified behavior, which will carry us safely through the present crisis, and guarantee the accomplishing of the next phase of the Plan of Evolution for this planet.

THE NEW GROUP OF WORLD SERVERS

"A strong subjective relationship exists between all servers of the Plan. This coherent, integrated group is transmitting spiritual energy throughout all areas of human thought and action to strengthen world unity and right human relationships. Men and women of goodwill link up in thought every day at five o'clock with this group of world servers, using the following brief dedication, silently and with focussed attention:

May the Power of the One Life pour through the group of all true servers.

May the Love of the One Soul characterise the lives of all who seek to aid the Great Ones.

May I fulfill my part in the one Work through self-forgetfulness, harmlessness, and right speech.

"This can be done in a few seconds of time wherever one may be. The new group of world servers is a subjectively organised group of men and women of all races, classes and creeds, who serve the Plan, humanity, the Hierarchy, the Christ and the Buddha, in their own way and in their own environment. The new group of world servers has no outer organisation, and no group or organisation is responsible for its activities." World Goodwill.

J.H., Mt. Laguna, California

"THE COMING OF THE GUARDIANS" by N. Meade Layne, (BSRF No. 3) 90 pages, illustrated, mimeo book, 8½x11, contains the 4-D explanation of the Flying Saucers and their reasons for being here. \$3.00

THE PROMISE, AND THE DANGERS, OF RADIONICS

"Riley, I've been keeping a regular line of letters going with Galen Hieronymous in Florida and I mentioned in my last letter to him that the only way to shock the government into action is to give them information that's strategic and impossible to know. Such as tracking the Polaris submarine Nathan Hale (with his radionics equipment). Galen has tracked the astronauts on Apollo 8 and 11, and has kept a running contact with the Skylab crew, but these are recorded phenomena. Everyone knows that a space shoot is in the works. But knowing the position of the Nathan Hale or the Thomas a. Edison or whatever classified sub is moving from point to point (the Pushkin?) would make the powers that be sit up and take notice. Any thoughts on the matter?"

M.B.R., Toronto, Ont., Canada

Yes, Galen Hieronymous has verified many times over the ERA (Electronic Reactions of Abrams) established experimentally by Dr. Abrams in San Francisco in the 1920s, using sophisticated radionics equipment of his own design. And, with his psychic tool he has offered himself as a medium to the United States government. In ancient Greek and Roman times such a man or woman was called an Oracle.

Back in the early 1960s dowser Verne Cameron offered to prove the efficacy of his Aurameter for the U.S. Navy at San Diego, so he told me. To certain unbelieving Naval officers he revealed, on their maps, the locations of two atomic-powered U.S. submarines, secret locations. The officers politely thanked him for his demonstration. There was no indication of how disturbed they might have been over this revelation of top secret information; nor did any of them offer to take a course in the use of the Aurameter.

As far as I know, Verne was aware of no followup reaction to his demonstration until he obtained a passport for his dowsing trip to Thailand. This is described in our book, "The Cameron Aurameter". He discovered at the consulate in Los Angeles that his passport was being held up on orders of the FBI. It wasn't until a military officer friend intervened for him that the passport was released. Thus you see the dangers of offering yourself to the government as a medium. The first reaction of people in authority is a thrill that here is a means of obtaining hidden military and political information. Their second reaction is that this Oracle must be taken into protective custody for fear that, if he or she gets into the hands of the enemy, the Oracle's abilities might be used against his own government! My advice to radionics experts with patriotic feelings parallels that of presidential assistant Gordon Strachan. Recently, in the Watergate hearings, minority counsel Fred Thompson asked him if he had any advice for other young men, ambitious to make a place for themselves in Washington.

"Yes," replied Strachan, "my advice to them is to stay out of government!"

APOLLONIUS, ORACLE FOR VESPASIAN

The Cappadocian Sage, Apollonius of Tyana -- the Paul of the New Testament -- knew only too well how dangerous it was to be a medium for dictators and other powerful leaders in his time, 2 A.D. to 92 A.D. He carried on his work of reforming the Mediterranean priesthods during the reigns of five Roman emperors. He found that sovereigns were eager to obtain secret information about their enemies, but revelations -- or the threat of revelations -- about their own secret evil actions could only lead to torture and prison.

In fact, the tyrant Nero became so incensed over the possible revelations of occult science that he ordered all philosophers expelled from Rome! The "H.R. Haldeman" of Nero's time, Tigellinus.



APOLLONIUS

Apollonius scrupulously avoided becoming involved in political intrigue; nevertheless he was brought before Tigellinus' inquisitors and a list of charges was drawn up against him. But Apollonius made use of the Mars power of his Geburah initiation. When he was brought to court to face the judge -- and the list of charges was unrolled to be read off -- the parchment was blank! The judge was so disgusted with the farce that he dismissed the case.

By the time Domitian murdered his way to the throne Apollonius was already being worshipped as a god by thousands of Romans, Jews, Thessalonians, Phillipians, etc., and his fame and occult powers had spread all over the Roman world. His scorn of tyrants and their surreptitious political activities were well known, too. The Tyanian Sage was summoned to an audience with Domitian, after having been arrested upon his arrival in Rome. The Emperor wanted this fount of wisdom kept in protective custody for his private use.

"You can detain my body but not my soul," replied Apollonius to the tyrant, "and I will add, not even my body."

He wrapped his cloak around him and vanished in a flash of light. Manly Hall, writing about this in his book, "The Phoenix", quotes H. P. Blavatsky as saying that Apollonius -- and his Inner Plane Guides and Protectors -- hypnotized the audience of thousands so Apollonius could walk out unseen and unhindered "to some secure retreat in the neighborhood and an hour afterwards his astral form appeared at Puteoli to his friends, and seemed to be the man himself."

THE FOOD AND DRUG WATERGATERS

"It was certainly a joyous time I had in California the past few weeks. At the largest seminar there was a scientist from Montreal, doctors from all over the country, and a Japanese expert on Acupuncture. So many are interested now in Laws of Natural Living and Natural foods. The Food and Drug agents were turned out en masse. We noted this and asked them to please stop their Watergate tactics, to come up to the front and use the table to take their tapes. I knew that some of them would be ashamed of their tie-pin, wristband, or hearing aid microphones and would decline; but we let them know that they, too, were welcome. Before, we have taken only the main tapes and asked others not to do so. However, it seemed that the ones that would need to use the tapes for reference did not have them, and the ones that were there, certainly not to learn but to spy on me, did have them, even though by their concealed methods they could not get a good one, and it was much harder to splice it up, cut parts out, take what I said out of context, and use it to further illegally persecute me. So we invited all to take any tapes that they wished. I can truly say that the new people I met while on this trip have certainly added a tremendous impact to my life and the things that I must do. The extended California visit was beautiful. So many realize that we are living at the end of an Age, the end of a System of Things, and the separation of the people as the Bible foretold is beautiful to behold!"

Ethel Toburen, Box 724, Kaneohe, Hawaii 96744

CALIFORNIA IS NOT BEAUTIFUL

"I felt very depressed while spending five weeks in Sun Valley, California. Vibrations were very negative. Was glad to be back home in New Mexico. Haven't you been guided by your Guardians to continue your work elsewhere? There must be some reason why your business has not grown. Time for a change in location? Hope you are not in Taurus, they do not take kindly to change."

E.M.D., Clovis, New Mexico

Not Taurus but Aries, with Moon in Libra and Gemini rising. So your Director does like change; but as I push on deeper into Kabbalistic studies, physical change becomes less important as there is increasing emphasis on emotional and mental changes. I don't have to go anywhere in searching for the Christ within.

We appreciate this concern about us and are well aware of the many and continuing doleful prophecies about this state. This concern was strongly expressed by a Georgia Associate who stopped by Headquarters on a recent extended summer trip. But consider her own experience when Atlanta was being "bombed" by terrible tornadoes in early summer. Lying in bed, unable to sleep because of the raging wind and rain, an unusually loud crash brought her bolt upright. Flashlight in hand she went into the living room. A dark, alien

object loomed before her. Reaching out hesitantly, the cold, wet, rough surface of bark told her that a huge tree-branch had crashed through the roof into the living room! The next tornadoe wasn't quite so bad, at least there were not falling trees close by, but nevertheless she awoke with the feeling that something wasn't right. Her pet dog jumped off the bed to investigate. She heard a splash! Putting her hand out and down, it went into cold water only six inches from the top of the bed! The nearby creek was flooding the neighborhood. One of her reasons for stopping by here was to replace BSRF literature drowned in the flood. Ironical, isn't it, that we should all be concerned about catastrophe elsewhere when we are all in the midst of it. The conflict of Piscean and Aquarian forces is disrupting life in all the form-levels of being, everywhere.

WASHINGTON IS NOT BEAUTIFUL, EITHER

"Dear Mr. Crabb: Every decent American is sickened and dismayed at the evidence of an official crime wave involving systematic corruption of our most cherished political and legal processes by many of the highest officers in our government. The reaction is not partisan. Here in Congress, our Republican colleagues share the Democrats' loathing and anger at the befouling of our heritage. And the atmosphere is thick with fear for the future of our country.

"Realization is spreading that Watergate, the destruction of evidence by the Acting Director of the FBI, the attempted rigging of the Pentagon Papers trial, and the other White House-centered deprivations of our system, involve precedents with the most dangerous consequences for our tripartite form of government. For what is at stake now is not just the effectiveness of the executive branch for the next few years, important as that may be, but the survival of our democratic system itself. What have been destroyed, and must be restored, are the mutual confidence and public trust without which no leaders, however able, can resolve the complicated problems of our nation.

"These pernicious precedents must not be allowed to stand. They must be extirpated, root and branch, together with anyone responsible for them. . . . Your alert attention and active participation are necessary for our success. It is important that concerned citizens continue to support those non-electoral citizens' groups which have worked so effectively to force exposure of hidden presidential campaign funds. And it is essential that you aid in the election of candidates of personal integrity who are committed to protecting and perfecting the democratic process. The liberal Senators who must run for re-election next year need your early and generous financial assistance.

"The seats of a dangerously high proportion of the Senate's most valuable members will be at stake in 1974 -- Senators such as Birch Bayh, Frank Church, Alan Cranston, Thomas Eagleton, William Fulbright, Harold Hughes, George McGovern, Gaylord Nelson, Abraham

Ribicoff, Adlai Stevenson and others. Highest priority White House effort and funds will be concentrated on retiring these Senators in 1974. This is a time which imposes special responsibilities on those who value the democratic process and understand the dangers of its corruption. If we are not assertive and vigorous in supporting the leaders who stand with us, their effectiveness will surely be impaired -- and they may fail altogether. Please make a generous contribution to the 1974 Campaign Fund and send it in the enclosed envelope today!"

Senators Philip A. Hart and Lee Metcalf
Senate Office Bldg, Washington, D.C.

Yup! Let's support the democratic process with enthusiasm. If we don't, our right and freedom to publish the Journal of Borderland Research will be destroyed by right-wing political fanatics.

"THE DEGREES OF THE ZODIAC SYMBOLIZED"

A fairly recent donation to our BSRF reference library is No. 8 of Alan Leo's Astrological Manuals, "The Degrees of the Zodiac Symbolized", published in England by L.N. Fowler & Co., and in Boston by F. Spenceley in 1907. From this we learn that each degree of each Sign of the Zodiac can be symbolized. This is an ancient and honored but lesser known aspect of Astrology. It was carried to a high degree of perfection thousands of years ago by Indian astrologers, according to Sepharial, who refined the art down to "every tenth part of a degree, or six minutes of space measured on the Ecliptic". Leo included in his No. 8 manual Sepharial's translation from the Italian of "La Volaspera" by Borelli.

Sepharial doesn't indicate where Borelli got his symbols, whether by inspiration or by earlier Indian or Egyptian works. He does mention the Theban Calendar "attributed to P. Christian, a man of singular occult attainments (in the Kabala and the Tarot), closely associated with the work of Eliphaz Levi" and another by Johannes Angelus "who wrote about the 16th Century, and whose work is embodied in 'The Faces and Degrees of the Zodiac' reprinted by Raphael. . . ."

Counting forward from March 21 (Your Director was born April 2, 1912, 9:25 a.m., Minneapolis, Minnesota) we come to Aries 13°. Borelli's symbol: "A man at the summit of a mountain illumined by the setting sun; holding a staff in his right hand, in his left a crown." Sepharial's interpretation: "It denotes one who through suffering, pain and hard work will at the close of life rise to much dignity and receive many honours. This degree is capable of lifting the native from obscurity to prominence as the reward of enduring effort. It is a degree of REWARD."

Just for fun let us turn now to one of the most prominent figures in world affairs and see if Borelli's symbols have any rel-

evance to his situation at the present time.

"A ROCKY EMINENCE IN THE MIDST OF A TURBULENT SEA"

Yes, you guessed it, President Richard Nixon, born Jan. 9, 1913, 9 p.m., Yorba Linda, California, a Los Angeles suburb. Here is Sefarial's interpretation of Borelli's symbol for 19° of Capricorn:

"This symbol denotes a character of great self-reliance, firmness, stability and originality, one who is capable of standing alone and combating with the steady resistance of enduring strength all the assaults of adverse fortune or popular displeasure. Alone, undaunted and impassive, he will stand amid the angry tumult of contending forces. He will show real strength and firmness that is born of conviction and direct perception of the truth. He cannot hope to be popular, but he cannot fail to be great and singular. The waves sweep on and dash themselves in futile wrath upon his moveless body. They are driven back, and expend themselves in seething comment and hissing impotence; he remains. It is a degree of STOLIDITY."

This would seem to indicate that Nixon has the inner resources and stability (and invisible connections) to survive the Watergate mess as he apparently intends to do. But we are reminded of the old saying: "God, protect me from my friends; my enemies I can take care of myself."

"KEY WATERGATE FIGURE DOOMED"

This headline strikes the eye from among the many news clips forwarded by Associates. This one is from the family weekly, "The National Tattler" for Aug. 12, 1973: "The prediction that a major Watergate figure will meet violent death within the year has been independently made by an alarming number of psychics and astrologers published in this newspaper. The dreadful forecast was not sought by TATTLER. Each of the seers -- all of whom hold remarkable records for accuracy -- came to the conclusion from an individual reading of the data available to him or her.

"The seers agree that the death will be a murder or a suicide, and two names appear in the forecasts with a regularity beyond the bounds of chance or speculation." The mention of two names would seem to indicate that fate has not yet decided which of two people close to the President will choose martyrdom -- or have it forced on them by an "arranged" suicide.

"Psychic Tenny Hale of Beaverton, Ore., named a prominent Watergate name and told TATTLER flatly: 'He will be dead within a few months. He may be a suicide. Before he is dead he will implicate the President in the Watergate matter. . . Leo Ellis Wagner, psychic of Los Angeles, revealed to TATTLER: 'A Watergate-related incident that is reported as suicide will actually be a killing.' . . Astrologer Dorothy O'Malia, on her radio show of July 4, 1971 predicted:

'If the President is re-elected, he will not finish his term, and it will not be due to illness.' (now) her own reading of President Nixon's zodiacal chart. 'Mr. Nixon's problems will become greater than he can handle. A chart such as his indicates that if he were a practicing lawyer, he would be disbarred; if a doctor, a revelation of malpractice. For the President, it represents disgrace, a fall.' . . . "

KETHER, THE CROWN, GOD THE CREATOR

The Supernal Triangle at the top of the Tree of Life gives us the occult relationship of a tripartite system of government. The leader of a nation is the Crown, representing the Will aspect of Creation. The Judiciary represents the 2nd or Wisdom aspect of Creation. The Legislature represents the 3rd or Love aspect of Creation.

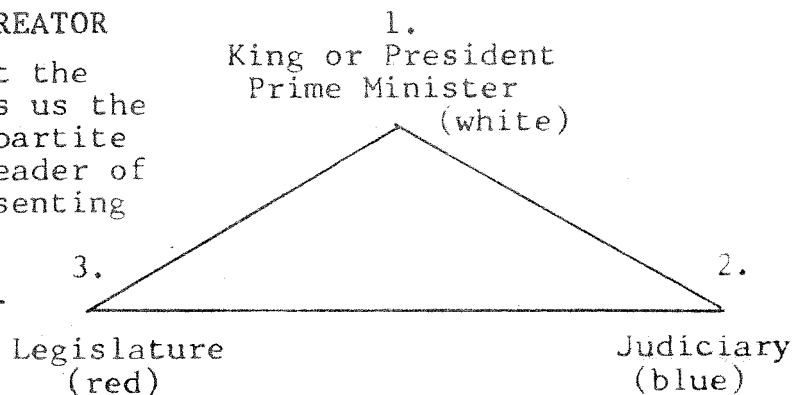

To better understand what makes and motivates a King, a Prime Minister or a President, we turn to Geoffrey Hodson's little book on "The Seven Human Temperaments". You Associates can use these revelations for a shrewd appraisal of any leader, whether you live in the United States or another country.

"The First Ray corresponds to the First Aspect, God the Father, the Creator. The preponderant qualities of the First Ray man are will, power, strength, courage, determination, leadership, independence, dignity, rising on occasion to majesty, daring and executive ability. This type of man (or woman!) is the natural ruler and leader, the statesman, the Empire-builder and colonizer, the soldier, the explorer and the pioneer. Alexander the Great was typical of this Ray when he went for more worlds to conquer. In the early stages of evolution these activities are largely physical. In the later phases they become mental and spiritual. The will is then exerted not so much as personal effort and strain, but in effortless, frictionless expression of the One Will.

"The ideal of the First Ray is strength, the First Ray man. . . fights to the end. . . He finds it difficult to tolerate weakness in any form and tends to despise those who give in. For him God, or the highest good, is the Principle of Power in all things. The greatest evils are weakness and surrender. The driving impulse is to attain and to conquer and such men are often seen at their best in adversity. . .

"Heedless of fatigue up to the point of utter exhaustion, the First Ray man exerts great mental and physical pressure upon himself and others and, when necessary, ruthlessly overrides or destroys all barriers and obstacles. (The revelation of Nixon's long

list of enemies within and without his own party, and his plans to have them harassed: character assassination, Internal Revenue Service audits, etc., are an example of this destroyer tendency.) As a teacher he accentuates self reliance. . . leaves pupils to stand alone as far as possible.

"The apotheosis is omnipotence, or to become consciously one with the divine Will. . . the ultimate objective of first Ray man is to fulfil a high office in the spiritual direction of the life of nations, planets and solar systems. Each life is therefore a training and a preparation for offices to be held in the future.

DEFECTS OF THE FIRST RAY TYPE

"Those displayed in the earlier stages of evolution are ruthlessness, hardness, stubbornness, pride, superciliousness, unadaptability, being ready to work only on lines which appeal personally, indifference to and even scorn of the opinions, rights and feelings of others, tyranny, thirst for power, egotism, braggadocio, extravagance, aggressiveness, wilfulness, assumption of superiority, mental rigidity and making final pronouncements upon debatable subjects, thereby closing discussion and prohibiting freedom of inquiry. (The President's coverup of the Watergate crimes and attempts to close off investigation are too well known now to require detailing here.) Dogma, or a supposedly authoritative statement, sometimes without regard to inherent truth or reasonableness, is used as a bludgeon to stun into silence enquiring minds.

"The greatest suffering can be experienced in defeat, degradation from office, displacement, humiliation, subordination and exile.

"The corresponding colour in the spectrum, generally present in the aura, is white tinged with electric blue at Egoic levels and bright vermillion in the personal aura. The jewel is the diamond and the symbol is that of the First Aspect of the Logos, the Creator, the 'One Alone', the circle with a point in the centre. Of the arts, dancing represents the First Ray. . . Amongst world religions, Hinduism displays the characteristics of the First Ray. . . "

It is likely that this life of President Nixon is the third of a series in which the Ego or Higher Self was single-mindedly directed toward the goal of becoming the leader of a great nation. Senator McGovern's defeat in the 1972 campaign could be taken as typical of the Nixon soul's experience in the previous life, perhaps in the early 1800s, when he tried and failed for high office; and before that he was probably some minor political figure in Europe, perhaps Ireland because of his Irish Catholic ancestry.

Three lifetimes to achieve an outstanding goal is a general principle of occult science. It takes that long in terms of earth time for the soul to organize its powers, choose physical plane surroundings with adequate challenges, defeats and successes to draw out those God-like powers.

PROJECT HERMES: TELECOMMUNICATIONS

"I'm working on the Hermes Project, not building it yet, just computing frequencies, which happen to be in the 8,000,000 Hz area. Once I get all the frequencies in place, from your BSRA No. 12 brochure, and a few ideas of my own, I will build the Project Hermes Telecommunicator and send you the details. And I will have a few questions in case you find another medium to verify frequencies and methods of use -- forehead, back of head, or free in space, etc. Enclosed is \$5.00 for a copy of the Five Rites of Rejuvenation and Teletherapy (if still available)."

W.F.Z., Jersey City, NJ

TESLA ON INTERPLANETARY COMMUNICATIONS

"This is from the Nikola Tesla article in the Century Magazine of June, 1900, titled: 'The Problem Of Increasing Human Energy':

'My measurements and calculations have shown that it is perfectly practicable to produce on our globe, by the use of these principles an electrical movement of such magnitude that, without the slightest doubt, its effect will be perceptible on some of our nearer planets, such as Venus and Mars. Thus from mere possibility interplanetary communication has entered the stage of probability. In fact, that we can produce a distinct effect on one of these planets in this novel manner, namely, by disturbing the electrical condition of the earth, is beyond any doubt. . . ' Much more on this and many other subjects in this one article. Copies of this can be ordered from Health Research, PO Box 70, Mokelumne Hill, California 95245."

Violet Barton, Hollywood, California

CRABB AND COMING LECTURE COMMUNICATIONS

"PSYCHIC SELF DEFENSE", an illustrated talk on the occult art of self-protection, complete with Workshop exercises on the Kabalistic Cross, Lesser Pentagram Ritual, etc., at the Anderson Research Foundation, 3968 Ingraham St., Los Angeles, California 90005, (213) 387-9164. This will be Friday evening, 8 p.m., September 21, 1973, donation \$2.00. Hope to see you LA area Associates there.

"PSYCHIC SURGERY IN ENGLAND", our dramatic reading of the famous interview between journalist J. Bernard Hutton and Dr. William Lang, English ophthalmologist who died in 1938. After years of specialization as an eye doctor in the flesh, Lang returned to general surgery as a spirit doctor, and carries on his earthly practice through medium George Chapman in Aylesbury. This talk will probably be in the afternoon of the Understandorama Seminar, Sunday October 28, 1973, Flamenco Room of Griswold's Claremont Inn, Foothill Blvd. and Indian Hill Road, Claremont, California. Donation \$3.00. Program will include five or six other speakers. For full information write or call Esther Ellsworth, Seminar Director, PO Box 626, Morongo Valley, California 92256, or (714) 342-6680.

"CLOSED CLASS WITH THE YADA"

Printed transcript of the Beginning and First Class on occult science with the Yada di Shi'ite in San Diego in 1967. This is an unparalleled opportunity to start occult studies and follow through with a Master teacher. Use the printed text for study, get the tapes for the warmth and flow of communication between Guru and Chelas. The text. . . \$2.00
Cassette Tape - Beginning - Two Hours - \$5.50
Cassette Tape - First Class - Two Hours - \$5.50
Beginning and First Class on Monaural, 3 3/4 speed, 7 in. reel - \$10.00

"TULKUS, A TIBETAN INITIATION"

Self-conscious Reincarnation through a series of lives was the way the Tibetan Lamas kept control of their power and wealth. This was a perversion of the Doctrine of the construction of the Solar Body or Body of Light, the only way to get out of the world alive! Wrong or right, it makes fascinating reading and study for the student of the occult. This 54-page, illustrated brochure describes the Way of the Yogin and is Lesson 12 in our series on "The Invisible Reality Behind Appearances" or the Western Mystery Tradition. \$2.00 postpaid. Also available on tape: Cassette, \$5.50. Monaural, 5 in. reel, 3 3/4 speed, \$5.50

THE INVISIBLE REALITY BEHIND APPEARANCES

Series of illustrated lessons on the Kabala of the Western Mystery Tradition. Lessons 1, 2 & 3 in one volume, 95 pages. . . . \$2.50
Lessons 4, 5 & 6, illustrated and with Workshops, 90 pages. . . . \$2.50
Lesson 7, "You Live In Four Worlds" illustrated, 68 pages and contains explanation of Pentagram Ritual for Psychic Self-defense. . . . \$2.00
Lesson 8, "The Four Ways to Freedom", adapted from one of Ouspensky's studies with Gurdjieff in St. Petersburg in 1916. These relate to the Four Worlds of the Kabalist and are called the Way of the Faqueer, the Monk, the Yogin, the Adept. All are described in this Lesson, with the emphasis on the Way of the Faqueer. 48 pages, illustrated. . \$2.00

FLYING SAUCERS AND THE NEW CONSCIOUSNESS

Revised edition of the Director's first UFO lecture in California in 1958, profusely illustrated with pix of UFOs and personalities. Discusses BSRA's 4-D explanation of the origin or materialization of the UFOs. Contains photos of Associate J. Gilber Wright's famous 1948 series on materializations in New York. . . . \$1.50

BINDING FORCE OF GRAVITY and schematic of Binding Force Meter, by W.B. Smith, 4-page reprint of Oct. 1963 Journal article. . . . 80c

EEMAN SCREENS, Self-Circulating Vitality brochure, illustrated. . \$1.50

RETRO ME, Rituals for Psychic Self-Defense. . . . 50c

VITIC or MAGNETIC VITALITY, from Magnet & Carbon, illustrated . . \$1.50

THE LAKHOVSKY MWO, regeneration of tissue with Tesla Coil . . . \$2.50

**COMING OF THE
GUARDIANS**

By Meade Layne

Contains the program of the Guardian UFOs for this planet, the 4-D explanation of their origin, types of Flying Saucers used in patrol work, comments of the Inner Circle on UFOs and notes on the Mark Probert mediumship. 90 pp. \$3.00

**FOUR WAYS
TO
FREEDOM:**

**The Way
of the
Faqueer**

Well ill-
ustrated,

48 pages
\$2.00



The JOURNAL of
Borderland Research

Bulk Rate
U.S. POSTAGE
PAID
Vista, Calif.
Permit No. 42

A Publication of:
Borderland Sciences Research
Foundation
PO Box 548
Vista, California
92083